



## **DVR2 electronic dynamo regulator & cut-out**

**(Field to Earth, Type B or Live Side regulation)**

### ***Introduction***

Benefit from fitting a DVR2 modern high quality 'solid state' electronic dynamo regulator . . .

- ◆ Brighter & more stable lighting (steady ammeter reading)
- ◆ Reliable charging from lower engine speed without overcharge
- ◆ Starts with a 'flat' battery or none at all, no low speed discharging
- ◆ Easier starting due to greater battery power
- ◆ Longer battery and bulb life
- ◆ Lower maintenance (no adjustments to regulator cut-out and less battery topping up)

DRL has made every effort to ensure a robust and reliable design, using up to date electronic components assembled using dependable 'surface mount' technology. Housed in a very presentable aluminium case. Compact size, electrically rugged and fault tolerant, with superior heat transfer to keep the circuitry cool for enhanced reliability.



## **Protection features**

The DVR2 is protected against voltage spikes from the dynamo or on the battery line, reverse polarity connection of the dynamo or battery, and will survive short circuit of the output. For full protection it is essential to fit a fuse in the line from the regulator output ('A' Terminal) to the ammeter or battery 'live' terminal. Fitting a fuse is good practice with either original equipment type 'CVC' regulators or an electronic replacement. Use a 12 to 15 Amp fuse for 6V, or a 10 Amp fuse for 12V.

## **6 or 12 Volts?**

Running a 6V dynamo at 12V using a DVR2 brings the benefits of brighter, cheaper bulbs, but requires increased dynamo speed over 6V operation. Sometimes charging may not be adequate during prolonged slow running. A Lucas E3L dynamo in good condition will safely provide 80W or more output at 12 V. Staying with 6V operation adds solid state zero-maintenance convenience to the system, and with modern bulbs gives good lighting at all practical speeds (provided that the wiring, switches and connectors are in good condition).

## **Fitting**

The DVR2 will fit inside Lucas or Miller cases or is easy to mount (and hide) on its own. Fixing is via a single M5 (5 mm diameter) stud. Size is 56 x 33 x 18 mm. The unit produces an exceptionally low level of heat, but if very heavy continuous loading is demanded it is wise to mount it in a flow of cooling air. The maximum safe continuous output current for the DVR2 electronics is 12 Amps, but this current would overheat many dynamos (for example the Lucas E3L) if prolonged.

## **Connections**

Before fitting the regulator it will be helpful to confirm your dynamo gives a good output of the correct polarity.

*Seek qualified assistance if you are unsure about fitting.  
Disconnect battery or remove fuse before connecting!*

Connect the five leads as follows (and study the wiring diagram):

**Black** lead (Negative Earth) *OR*

**Red** lead (Positive Earth) to **E**arth / frame / chassis

**Green** lead to **F**ield

**Yellow** lead to **D**ynamo

**Brown** lead to **A**mmeter

**White** lead to **Brown** lead for 6 V operation

**White** not connected (insulated) for 12 V operation

*Don't forget to refit the fuse!*

## Typical DVR2 connections

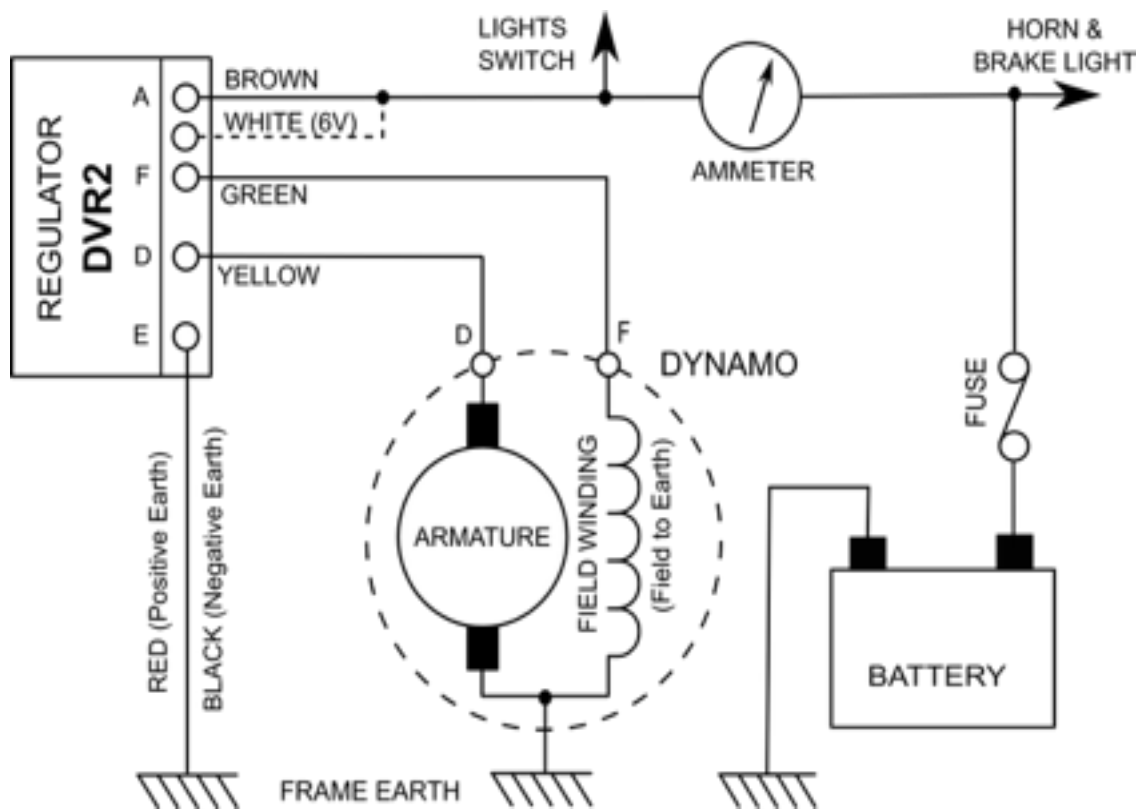

### Charging Checks

After the DVR2 has been connected check all connections one more time according to the diagram above. Make sure that the dynamo is well earthed (no paint or corrosion blocking the current path). Start the engine and slowly increase speed until a small charge is shown on the ammeter. If this is not seen at about one third maximum revs, stop and check again.

Measure the regulated output voltage at **A** (other lead to earth **E**). The regulator output should stabilise at 7.2 or 14.2 Volts as the speed is increased. In normal operation only a slight 'trickle charge' should be seen on the ammeter (about ½ to 1 amp). A high charging current shown for a long period may indicate a very low or faulty battery or other problem requiring attention.

### Guarantee

The DVR2 is guaranteed for one year from purchase against manufacturing defects, but not for faults caused by improper fitting or use. If a fuse is not fitted as described above any claim for damage may be rejected.

***If you are in any doubt about fitting this electronic regulator correctly please seek the assistance of a competent person!***

## **Other Notes**

- ◆ The resistance of the dynamo field winding *must* be greater than 2.5 ohms. If less the dynamo will be very inefficient and there is a real risk of damaging the regulator.
- ◆ Disconnect or remove any field resistor which may be fitted at the dynamo or elsewhere (wire-wound item connected to field terminal). Ensure that the field wire of the dynamo goes to the F terminal of the DVR2, and that no other wire is connected. *Failure to do so may result in overcharging and possible damage to equipment.*
- ◆ The DVR2 is *not suitable for use with 3 brush* dynamos. However, usually the 3 brush dynamo can easily be converted to a 2 brush unit.
- ◆ The DVR2 is not designed for use with a large capacitor (e.g. Lucas 2MC) at the output.
- ◆ The metal case of the DVR2 is not connected to the 'earth' lead. If the earth connection via the lead is lost the dynamo output voltage will not be regulated.



**Lucks Green Cottage, Horsham Road, Cranleigh, Surrey GU6 8DP**

**UK Reg. No. 07295701**

**<http://www.dynamoregulators.com>**

**Tel: +44 (0) 1483 276615**

**e-mail: [dvr@dynamoregulators.com](mailto:dvr@dynamoregulators.com)**